



27 CU. FT. GLASS DOOR MERCHANDISER

KCGM27F

FREEZER



Dynamic Condenser improves performance in high temperature environments

Automatic Defrost Cooling System provides worry-free performance

1-1/3 HP Compressor

Painted Steel/Painted Aluminum Exterior & Interior

Electronic Controls

External Temperature Display

Removable Door Gaskets

Adjustable Shelves Vinyl-Coated Steel

Self-Closing Swing Doors

Heavy Duty Casters



TECHNICAL SPECIFICATIONS

MODEL	KCGM27F
Product Line	Freezer
Door(s)/Type	2 Door Swing
Capacity (Cu. Ft.)	27.0
Condenser Type	Dynamic
Automatic Defrost Cooling System	Yes
Compressor Horsepower	1-1/3
Exterior Finish	Painted Steel
Interior Finish	Painted Aluminum
Shelves (Number/Type)	8/Vinyl-Coated Steel
Control	Electronic
Temperature Display Location	External
Temperature Range	-7 to 10°F
Voltage Rating	115V/60Hz
Run Amps	9.6
Plug Type	NEMA 5-20P
Shipping Weight (Lbs.)	442
Warranty	3 Year/5 Year

Electronic Digital Temperature Control

Quick set digital control and display for easy monitoring.



Vinyl Heavy Duty Adjustable Shelves

Shelves that are easy to handle and keep clean.



Removable Door Gaskets

User replaceable door gaskets for easy replacement and cleaning.





27 CU. FT. GLASS DOOR MERCHANDISER

KCGM27F

FREEZER

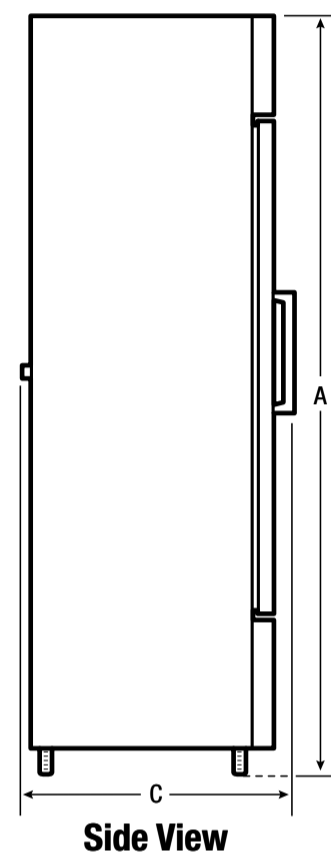
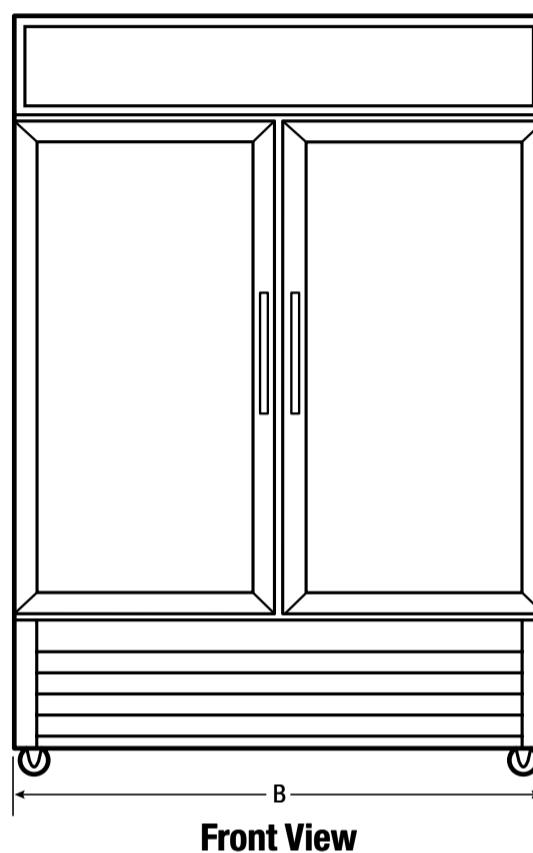
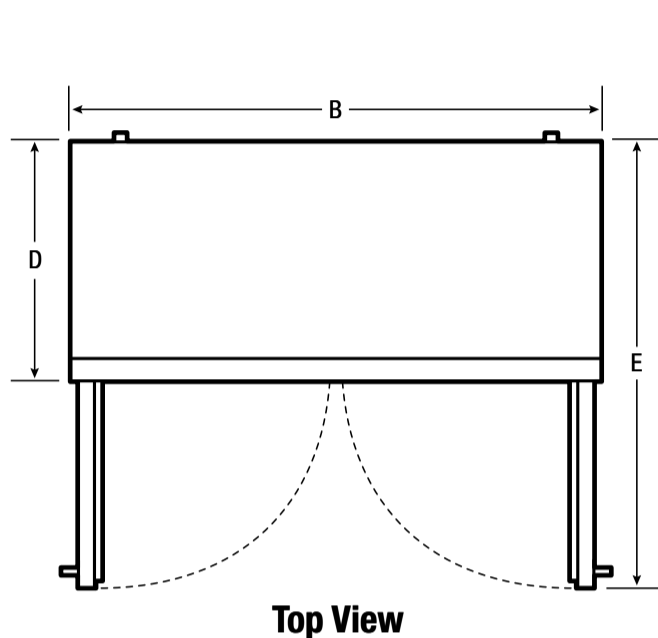

Plug Type (NEMA)
5-15P

EXTERIOR DIMENSIONS

Height A (Including Casters)	80"
Width B	49"
Overall Depth (Including Door & Handle) C	28"
Cabinet Depth D	26"
Depth (with Door 90° Open) E	49"

CERTIFICATIONS AND APPROVALS

Safety Certification	ETL
Sanitation Certification	ETL

ACCESSORIES

Shelf	5304487387
Shelf Clip	297121900



USA • 10200 David Taylor Drive • Charlotte, NC 28262 • 1-866-738-1640 • kelvinator.com
CANADA • 5855 Terry Fox Way • Mississauga, ON L5V 3E4

KCGM27F 06/15

© 2015 Electrolux Home Products, Inc.

High standards of quality at Electrolux Home Products, Inc. mean we are constantly working to improve our products. We reserve the right to change specifications or discontinue models without notice.