



COMMERCIAL RESIN FURNITURE

*Your best value for Food Service & Hospitality!*

# Miami Bistro Stacking Sidechair

**Passes ASTM F 1561-96 Class B  
performance standard for commercial outdoor seating**

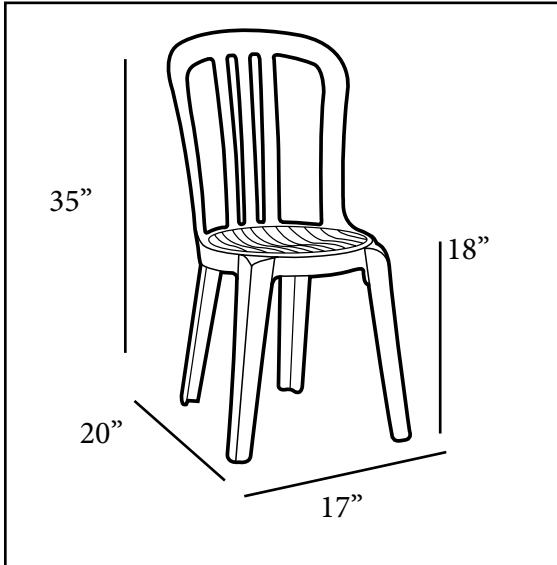

**Features & Benefits** **Warranty: 3 Yrs.**

- There is more to this stacker than meets the eye. This chair adjusts to your body weight to provide optimum comfort.
- Rated to 300 pounds for safe use in commercial environments.
- Chair made of 100% prime synthetic resin. U.V. stabilized for greater resistance to sun degradation and changing weather conditions.
- High, contoured and flexible back joints with a shaped seat for extra comfort.
- Glossy and matte alternating stripes further enhance the design of the seat.
- One-piece molded construction. Stacks easily, nests closely.
- Extremely durable. Easy to maintain; just a wet sponge and a drop of a mild liquid detergent will restore this chair to a fresh new look.
- Versatile; this staple of the industry was made and designed by Grosfillex for terraces, cafes, concessions, balconies, parks and special events in the great outdoors.

<b>Product Specifications</b>						
Product Description	Reference Number	Color	UPC Code 014306	Weight Each (lbs.)	Master Pack	Master Pack Volume (cu. ft.)
Miami Bistro Stacking Sidechair	US495504	White	100425	7.09	32	43.18
	US495004	White	100425	7.75	4	10.59
	US495517	Black	100197	7.09	32	43.18
	US495017	Black	100197	7.75	4	10.59
	US495578	Amazon Green	100463	7.09	32	43.18
	US495078	Amazon Green	100463	7.75	4	10.59
	US495502	Charcoal	136400	7.09	32	43.18
	US495002	Charcoal	136400	7.75	4	10.59
	US495019	Orange	917399	7.09	32	43.18
	US490019	Orange	917399	7.75	4	10.59
	US495152	Fern Green	917405	7.09	32	43.18
	US490152	Fern Green	917405	7.75	4	10.59
	US495414	Red	917412	7.09	32	43.18
	US490414	Red	917412	7.75	4	10.59
	US495181	Taupe	917429	7.09	32	43.18
	US490181	Taupe	917429	7.75	4	10.59