



BEVERAGE-AIR

3779 Champion Blvd., Winston-Salem, NC 27105
1-888-845-9800 Fax# 1-336-245-6453
<http://www.Beverage-Air.com>

Commercial Refrigeration Equipment General Specification

UCR/UCF SERIES UNDERCOUNTER UNITS

Whenever space is a limiting factor and health inspection approval is critical, compact, shallow-depth refrigerators and freezers have provided the answer.

CABINET CONSTRUCTION

Models feature construction with stainless steel exteriors and aluminum interiors.

Cabinets are insulated with 2" thick CFC and HCFC-free foamed-in-place polyurethane insulation for maximum energy conservation and structural integrity. Doors are mounted to cabinet on heavy duty self-closing, cartridge style hinges with 120° stay open position. Doors are equipped with a snap-in-place vinyl magnetic gasket for positive seal. Convenient, double pull style door handle is made of black anodized aluminum. 6" high legs are standard. Cabinet interior standard with 2 steel wire epoxy coated shelves per section.

REFRIGERATION

Balanced refrigeration systems provide refrigerator holding temperatures of 35° to 38° range. Freezer model temperature is held at zero and below. Refrigerants used are R134a in the refrigerators and 404a in the freezer. Both are CFC and HCFC-free providing full compliance with environmental concerns. Interior forced-air system with high humidity evaporator coils, provides the ideal environment for food preservation.

ELECTRICAL

Units wired at factory and ready for connection to a 115/60/1 phase, 15 amp dedicated outlet. 8' long cord and plug set included.

SPECIAL FEATURES

- Cartridge style door hinges provides positive seal & eliminates door sagging issues (excludes glass door and some special units).
- Optional 3" or 6" casters available

Item No. _____
Quantity _____

SHALLOW DEPTH UNDERCOUNTER REFRIGERATORS AND FREEZERS FOOD PREPARATION SERIES

MODELS:
UCR20
UCF20
UCR27
UCF27
UCR34



UCR / UCF20



UCR / UCF27



UCR34

ELECTRICAL CONNECTION

Units pre-wired at factory and include 8' long cord and plug set.



115/60/1
NEMA-5-15P

Available From:



Model Specified _____	Store# _____
Location _____	Quantity _____



BEVERAGE-AIR

**Shallow Depth
Undercounter Refrigerators/Freezers**
Models: UCR20Y, UCF20, UCR27Y, UCF27, UCR34Y

MODEL	UCR20Y	UCF20	UCR27Y	UCF27	UCR34Y
EXTERNAL DIMENSIONAL DATA					
Length Overall (inches)	20"	20"	27"	27"	34"
Length Overall (mm)	508	508	686	686	864
Depth Overall (inches) - Less handle	22"	22"	27 3/4"	27 3/4"	23 5/8"
Depth Overall (mm) - Less handle	559	559	705	705	600
Height Overall—on 6" legs (inches)	31 1/8"	31 1/8"	34 1/2"	34 1/2"	31"
Height Overall—on 6" legs (mm)	791	791	876	876	787
Depth with Door Open 90 °	40 1/2"	40 1/2"	53 1/4"	53 1/4"	38"
Clear Door Opening (inches)	15 3/4" x 18 3/16"	15 3/4" x 18 3/16"	22 1/2" x 21 3/8"	22 1/2" x 21 3/8"	13/ 1/8" x 18"
Number of doors	1	1	1	1	2
INTERNAL DIMENSIONAL DATA					
NET Capacity (cubic ft.)	2.7	2.7	6.2	6.2	5.5
NET Capacity (Liters)	77	77	176	176	156
Internal Length Overall (inches)	16"	16"	23"	23"	29 3/8"
Internal Length Overall (mm)	406	406	584	584	746
Internal Depth Overall (inches)	13"	13"	18"	18"	17"
Internal Depth Overall (mm)	330	330	457	457	432
Internal Height Overall (inches)	19"	19"	23"	23"	19"
Internal Height Overall (mm)	483	483	584	584	483
Number of shelves	2	2	2	2	4
ELECTRICAL DATA					
Full Load Amperes 115/60/1	3.0	5.3	4.0	6.0	4.0
ENERGY CONSUMPTION (KWH)	2.73	6.18	2.79	N/A	3.12
REFRIGERATION DATA					
Horsepower	1/6	1/4	1/6	1/4	1/5
WEIGHT DATA					
Gross Weight (Crated lbs)	119	130	157	162	165
Gross Weight (Crated kg)	54	59	71	74	75

PLAN VIEWS

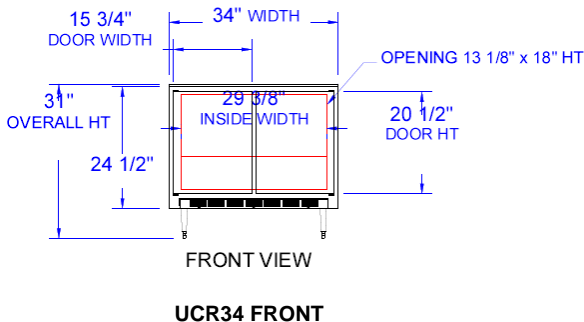
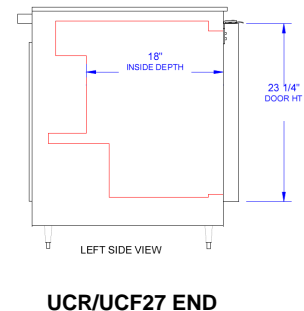
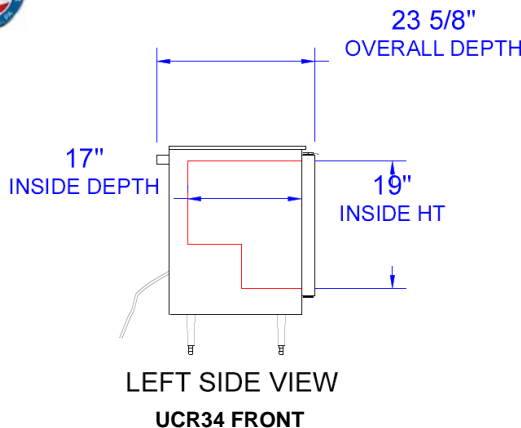
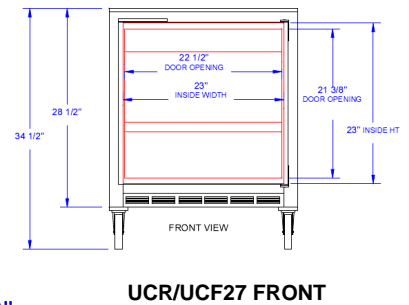
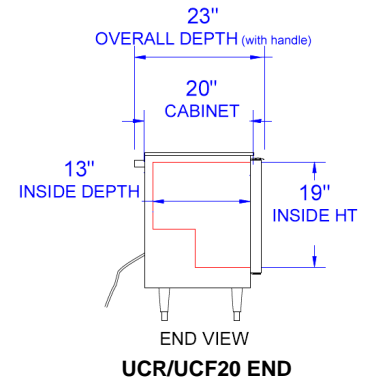
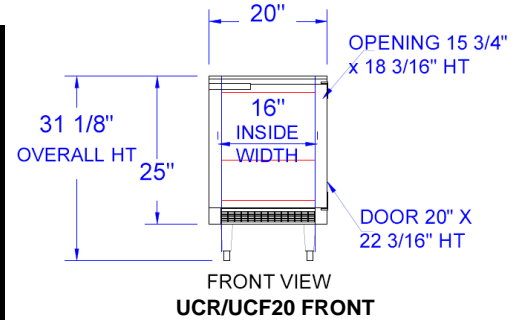

BEVERAGE-AIR® CORPORATION

3779 Champion Blvd. • Winston-Salem, NC 27105 USA • (336) 245-6400 • Fax (336) 245-6453 • (888) 845-9800 • www.beverage-air.com

Specifications are subject to change without prior notice. 10/11