



BEVERAGE-AIR

3779 Champion Blvd., Winston-Salem, NC 27105
1-888-845-9800 Fax# 1-336-245-6453
<http://www.Beverage-Air.com>

Commercial Refrigeration Equipment General Specification

VUEMAX SERIES—OPEN-AIR MERCHANDISERS

Three different sizes to choose from (7, 12 or 18 cubic feet).
Certified for packaged product. Ideal for gourmet shops, delicatessens,
convenience stores and bakeries.

CABINET CONSTRUCTION

Exterior finish is heavy-duty steel with a baked on durable paint.
Gray exterior finish with stylish impact bumper for added protection.

Foamed-in-place CFC free polyurethane insulation enhances the struc-
tural strength of the cabinet and helps increase energy efficiency.

Glass sides constructed to enhance product visibility from different
angles.

Shelves included can be installed in 2 positions for display flexibility.

Night curtain comes standard and helps save energy and maintain
cabinet temperature.

6" adjustable legs standard.

REFRIGERATION

Whisper-quiet refrigeration system uses R134a refrigerant, which is
CFC-free for compliance with environmental safety concerns.
Maintenance-free condenser slides out for easy service.

Electronic temperature control displays internal cabinet temperatures.
Operating temperatures from 36°F to 38°F.
Intended for use in rooms having ambient conditions of
75°F/55% relative humidity.

ELECTRICAL

Excellent interior lighting enhances product illumination.

SPECIAL FEATURES

- Night curtain standard
- Stylish impact bumper
- 6" adjustable legs standard
- 5" casters (optional) add versatility
- Security cover (optional) helps keep your merchandise secure
outside normal business hours.
- Custom graphics available. Contact factory for more information.

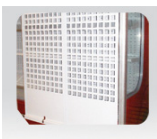

SECURITY CAGE



NIGHTBLIND

Item No. _____
Quantity _____

VUEMAX OPEN-AIR MERCHANDISER SERIES

MODELS:
VM7
VM12
VM18

VUEMAX is certified for
bottled beverage and
packaged food product



VM7



VM12



VM18



Gray exterior is standard. Black and white exterior
options are available. Contact factory for availability
and lead time.

Available From:



Model Specified _____

Store# _____

Location _____

Quantity _____



BEVERAGE-AIR

VueMax Open-Air Merchandisers

Models: VM7, VM12, VM18

PLAN VIEWS

MODEL	VM7	VM12	VM18
EXTERNAL DIMENSIONAL DATA			
Length Overall (inches)	35"	35"	51"
Length Overall (mm)	889	889	1295
Depth Overall (inches)	31"	31"	31"
Depth Overall (mm)	787	787	787
Height Overall— (inches)	59"	79"	79"
Height Overall— (mm)	1499	2007	2007
INTERNAL DIMENSIONAL DATA			
NET Capacity (cubic ft.)	7	12	18
NET Capacity (Liters)	198	340	510
Number of shelves	3	4	4
ELECTRICAL DATA			
Full Load Amperes 115/60/1—Breaker required	15	20	30
Amp Draw	8	11	16
REFRIGERATION DATA			
Horsepower	1/3	2 of 1/4	2 of 1/3
WEIGHT DATA			
Gross Weight (Crated lbs)	415	507	525
Gross Weight (Crated kg)	188	230	238

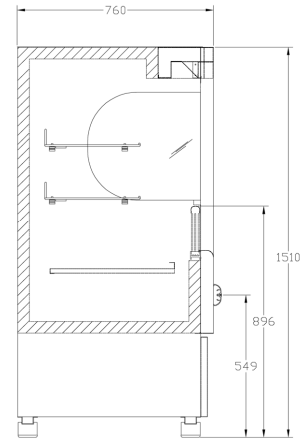
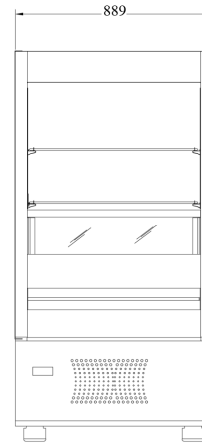

VM7

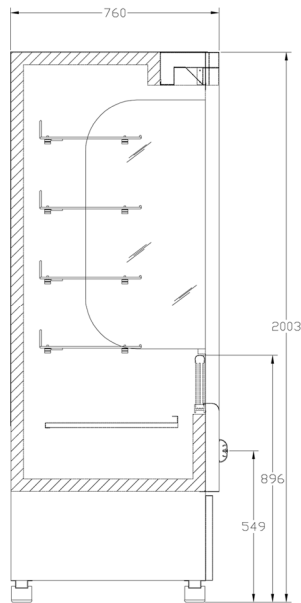
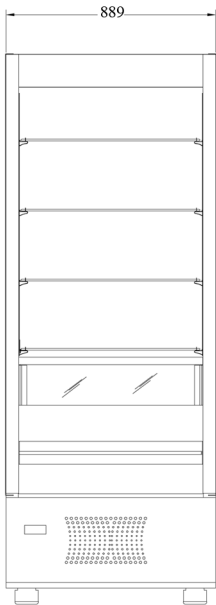

VM12

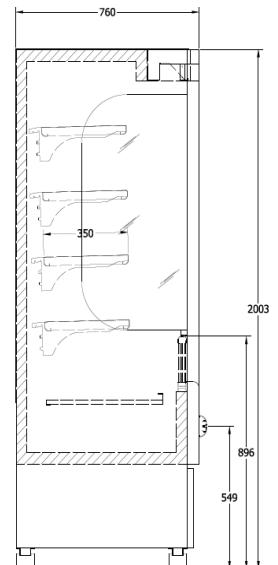
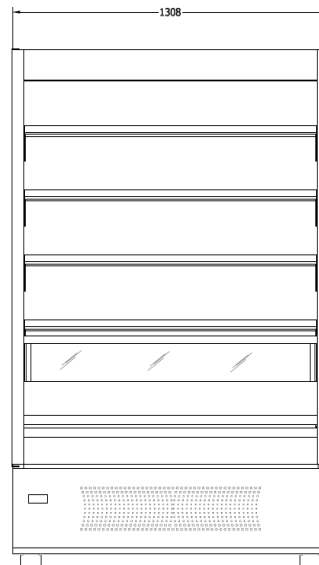

VM18

BEVERAGE-AIR® CORPORATION

3779 Champion Blvd. • Winston-Salem, NC 27105 USA • (336) 245-6400 • Fax (336) 245-6453 • (888) 845-9800 • www.beverage-air.com

Specifications are subject to change without prior notice. 02/11