



Project _____

Item No. _____

Quantity _____

Model VF35 Tube Fired Gas Fryer



STANDARD ACCESSORIES

- Tank-stainless steel
- Cabinet - stainless front, door and sides
- One tube rack
- One built-in flue deflector
- Two twin size baskets
- One drain extension
- One drain line clean-out rod
- Removable basket hanger for easy cleaning
- 9"(22.9cm) adjustable legs, easier access to clean

AVAILABLE OPTIONS & ACCESSORIES

- Tank Cover
- 9"(22.9cm) Casters

STANDARD SPECIFICATIONS

CONSTRUCTION

- Welded tank with an extra smooth peened finish ensures easy cleaning.
- Long lasting, high temperature alloy stainless steel heat baffles are mounted in the heat exchanger tubes to provide maximum heating and combustion.
- Standing pilot light design provides a ready flame when heat is required.
- Stainless steel front, door, sides and splash back.

CONTROLS

- Solstice burner/baffle design.
 - Increases cooking production
 - Lowers flue temperature
 - Improves working environment
 - Generates more production per BTU
- Thermostat maintains selected temperature automatically between 200°F (93°C) and 400°F (190°C).
- Integrated gas control valve acts as a manual and pilot valve, automatic pilot valve, gas filter, pressure regulator, and automatic main valve.
- Gas control valve prevents gas flow to the main burner until pilot is established and shuts off all gas flow automatically if the pilot flame goes out.
- Temperature limit switch safely shuts off all gas flow if the fryer temperature exceeds the upper limit.

OPERATIONS

- Front 1-1/4" NPT drain valve, for quick draining

Model VF35 Tube Fired Gas Fryer



Model VF35 Tube Fired Gas Fryer

- (G) 3/4" NPT GAS CONNECTION. CE MODELS USE A 3/4" INCH BSP ADAPTOR ADDING 1-1/2" (3.8) TO THE CONNECTION
- (D) 1-1/4" NPT (3.2 CM) NPT FULL PORT DRAIN VALVE

Model VF35 Tube Fired Gas Fryer

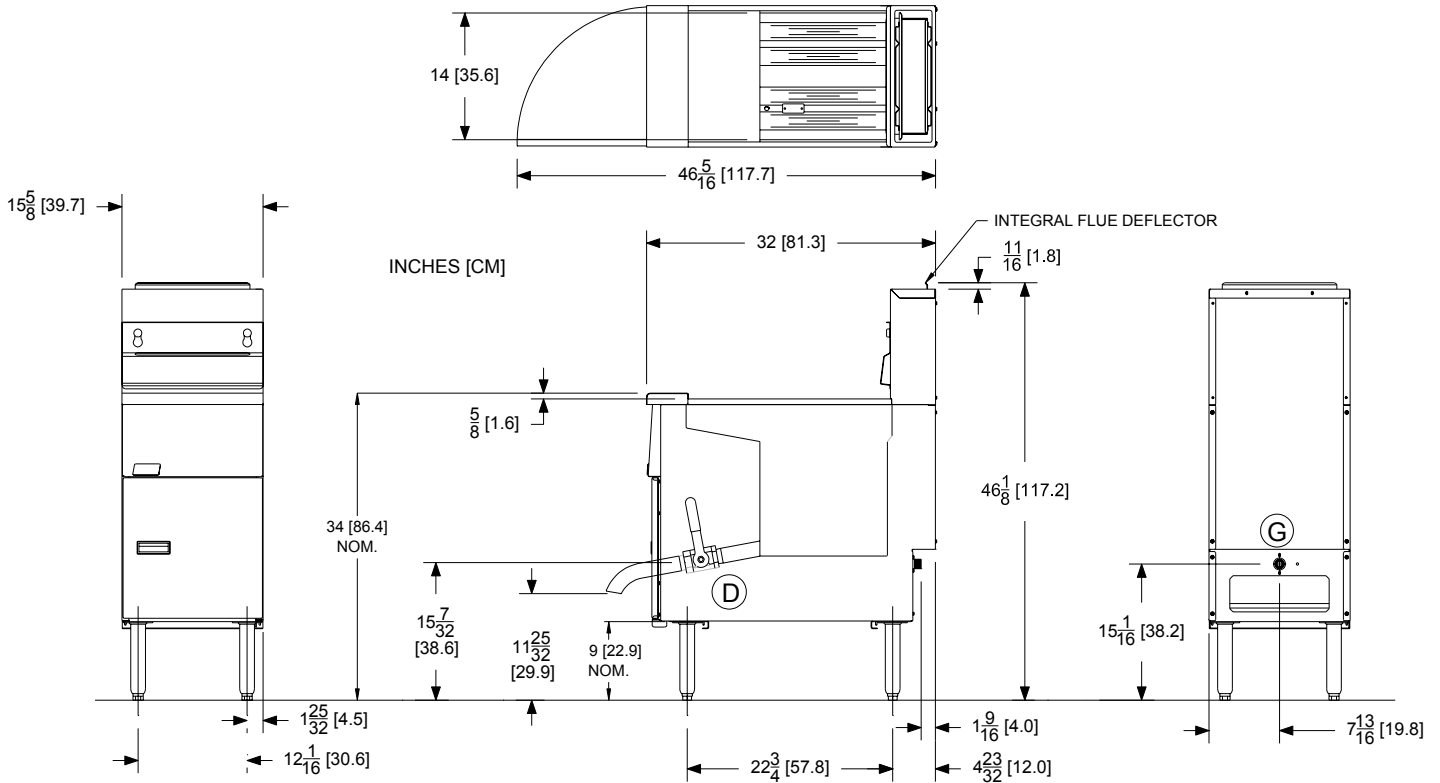

ELECTRICAL	OIL CAPACITY
No Electrical options available	35 lbs (15.9 kg)
SHIPPING INFORMATION (H x W x L)	SHIPPING INFORMATION (Approximate)
36 x 19 x 46 in (116.8 x 48.3 x 91.4 cm)	181 lbs (82.1 kg) 18.2 ft ³ (0.5 m ³)
GAS CONSUMPTION	PERFORMANCE CHARACTERISTICS
70,000 BTU's/Hour (20.5kW) (74MJ/hr)	Cooks 55-59 lbs. (24.9-26.7kg) of fries per hour. Frying area is 14" x 13-5/8" x 4" (35.6 x 34.6 x 10.2 cm)
SHORT FORM SPECIFICATION	
Provide Pitco VF35 tube-fired gas fryer. Fryer shall have an atmospheric burner system combined with three stainless steel tubes utilizing high temperature alloy stainless steel baffles. Fryer shall have a deep cool zone; minimum 13% of total oil capacity. Fryer cooking area shall be 14" x 13-5/8" (35.6 x 34.6 cm) with a cooking depth of 4" (10.2 cm). Heat transfer area shall be a minimum of 431 square inches (2780 sq cm).	
TYPICAL APPLICATION	
Frying a wide variety of foods in a limited amount of space. Frying that requires a medium volume production rate.	

