



SE36 SERIES ELECTRIC RANGE

Convection Oven SE36A

Standard Oven SE36D



SE36A-TTB
with optional
casters and
marine kit.

Job
Item#

9" solid round hotplates are controlled by an indicating 3-heat switch. The 12" x 24" hotplate sections on the HHH, HHB and TTH are controlled by a thermostat with a temperature range of 250°F to 850°F. The griddle sections on the TTT, TTB and TTH are controlled by a thermostat with a temperature range of 150°F to 450°F. Range is provided with a 2 hour timer adjustable from 6 to 120 minutes (timer has a bell signal). The oven temperature is controlled by a thermostat adjustable from 150°F to 450°F. Each thermostat is provided with an "OFF" position. Each 9" diameter hotplate is provided with a 4-position, 3-heat switch "HIGH"/"MEDIUM"/"LOW" and "OFF" settings. An indicator light is associated with each thermostat, indicating when preset temperature is reached and cycles on or off. Oven section includes a "HIGH"/"LOW" fan speed switch.

Application

You can saute, braise, pan fry, griddle, boil, stew, simmer, bake, brown, roast and reconstitute with the Southbend heavy-duty range.

General Information

Heavy-duty electric range with deck oven or convection oven base. Range is 36"W x 38-1/2"D x 38-1/4"H including legs.

Construction

The frame of the range and oven is welded aluminized steel with stainless steel front, sides, top and back. Grease troughs are located at front and rear for drainage, with grease chutes into two wide, drawer-type receptacles. The griddle models are furnished with splash guards surrounding back and side of the griddle section. Range is 100% front serviceable.

Convection Oven (SE36A)

The convection oven is provided with stainless steel inner lining, stainless steel throat, vent with damper and shelf-type, stainless steel lined door. Removable rack supports to accommodate six racks are installed on the interior sides of the oven. The blower fan is powered by a sealed ball bearing motor. Oven is fully insulated on all sides.

Standard Oven (SE36D)

The deck oven is provided with aluminized steel inner lining; removable deck of rigidized steel; vent with damper; and shelf-type, stainless steel lined door. The oven is insulated on all sides.

Electrical

Wiring is connected at a terminal compartment in the base. Knockouts are provided in the bottom and back for power supply entrance. See electrical data for kW rating of range tops and ovens.

Heating

Heating is accomplished with formed tubular elements clamped underneath each griddle and rectangular hotplate. The TTT has 4 heating sections for the 36" x 24" griddle. The TTB and the TTH have two heating sections under the 24" x 24" griddle. The oven heating element is located on the side of the cavity encircling the oven blower fan. Oven will preheat to 450°F in 20 minutes.

Controls

Range-top section controls are mounted in a central ventilated control panel, hinged for easy service access.

Convection Oven Capacity

The convection oven has a capacity for (6) 20-7/8" x 28-1/4" racks. Three racks with positive stops are furnished. Oven has a clearance height of 13-1/4".

Standard Oven Capacity

The standard oven is provided with a slide out removable rack. Oven has a total meat capacity of 60 lbs. Oven has a clearance height of 12-1/2".

Each oven rack will accommodate (2) 12" x 20" #200 pans, (1) 18" x 26" roll pan, (1) 18" x 24" meat pan, (10) standard 1 lb. loaf pans or (6) 9" pie tins.

Warranty

Warranted for one year covering parts and labor.

Ordering Information

Basic Models - 208VAC or 240VAC or 480VAC (3 phase) voltage must be specified. Specify "assembled" or "hatchable". Hatchable is packaged in two sections that can pass through a 26" wide door for assembly in kitchen.



Models: SE36D SE36A

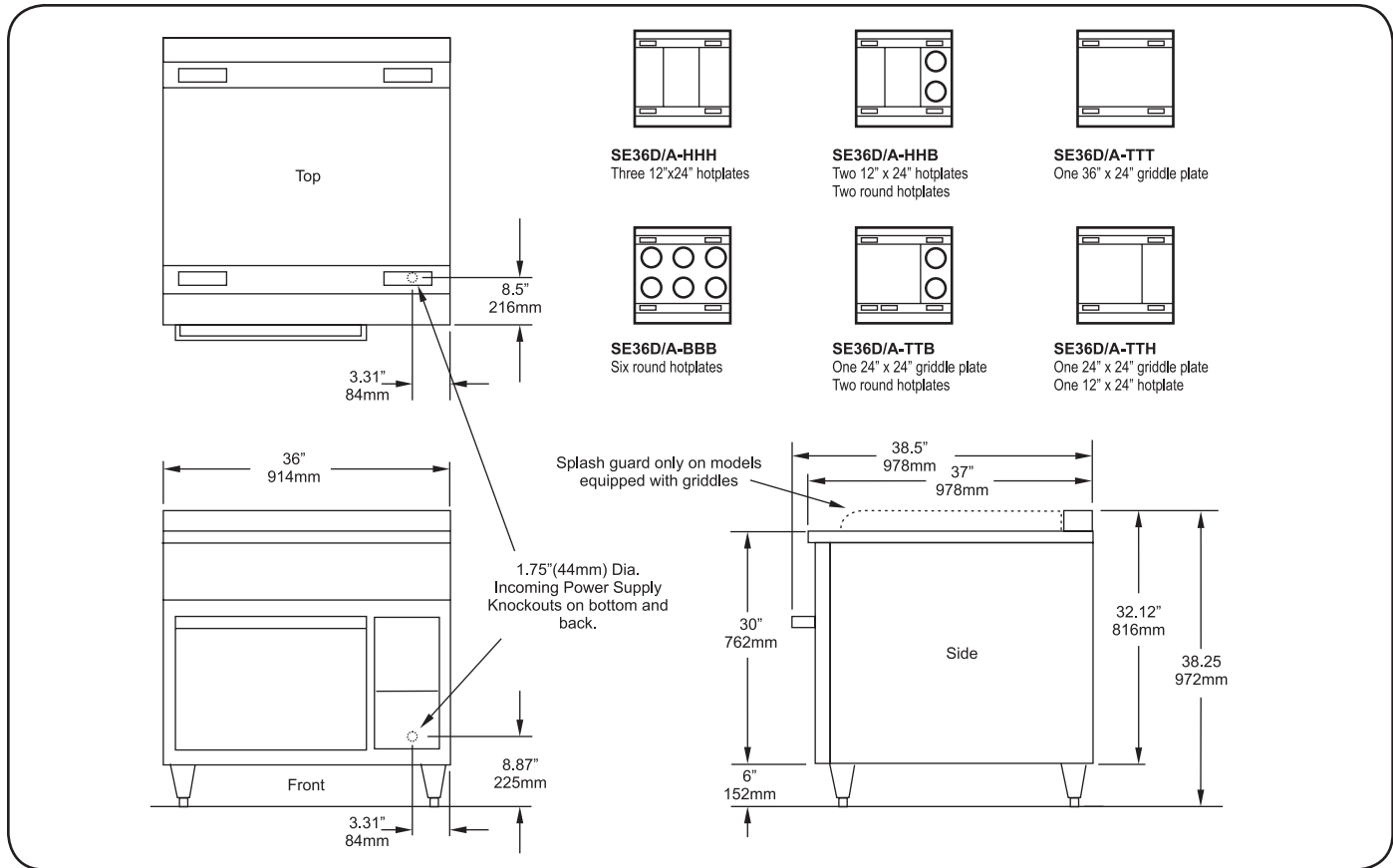

UTILITY INFORMATION

Model	in(mm) Height	in(mm) Width	Depth Overall	Convection Oven kW	Standard Oven kW	Range Top kW	12" x 24" Hotplate kW (QTY)	9" Round Hotplate kW (QTY)	Griddle Heating Element kW (QTY)	Installed	Weights lbs(kg) Ship/Hatch	Ship/Assm	
SE36-HHH	36(914)	36(914)	38.5(978)	6.0	6.0	15.9	5.3 (3)	-	-	599(271.7)	700(317.5)	654(296.6)	
SE36-HHB	36(914)	36(914)	38.5(978)	6.0	6.0	15.8	5.3 (2)	2.6 (2)	-	559(253.5)	660(299.4)	624(283.0)	
SE36-TTT	36(914)	36(914)	38.5(978)	6.0	6.0	16.5	-	-	4.125 (4)	599(271.7)	700(317.5)	654(296.6)	
SE36-BBB	36(914)	36(914)	38.5(978)	6.0	6.0	15.6	-	2.6 (6)	-	549(249.0)	650(294.8)	627(284.4)	
SE36-TTB	36(914)	36(914)	38.5(978)	6.0	6.0	15.8	-	2.6 (2)	5.3 (2)	559(253.5)	660(299.4)	624(283.0)	
SE36-TTH	36(914)	36(914)	38.5(978)	6.0	6.0	15.9	5.3 (1)	-	5.3 (2)	559(253.5)	660(299.4)	624(283.0)	
Conv Oven Models	Total kW	3 Phase Loading kW per Phase			208V			240V			480V		
		X-Y	Y-Z	X-Z	X	Y	Z	X	Y	Z	X	Y	Z
SE36A-HHH	21.9	6.0	10.6	5.3	49.2	72.0	67.4	43.0	62.6	58.4	21.9	31.6	29.2
SE36A-HHB	21.8	6.0	10.5	5.3	49.2	71.4	67.0	43.2	62.4	58.0	21.9	61.5	29.0
SE36A-TTT	22.5	6.0	8.25	8.25	51.6	61.6	68.7	53.9	55.9	59.5	27.2	27.2	29.8
SE36A-BBB	21.6	6.0	7.8	7.8	59.6	59.6	65.0	52.2	52.2	56.3	26.4	26.4	28.1
SE36A-TTB	21.8	6.0	10.5	5.3	71.4	49.2	67.0	62.4	43.2	58.0	31.5	21.9	29.0
SE36A-TTH	21.9	6.0	10.5	5.3	49.2	72.0	67.4	43.2	32.8	58.3	21.9	31.6	29.2
Std Oven Models	Total kW	3 Phase Loading kW per Phase			208V			240V			480V		
		X-Y	Y-Z	X-Z	X	Y	Z	X	Y	Z	X	Y	Z
SE36D-HHH	21.9	6.0	10.6	5.3	47.1	70.0	67.4	40.8	60.7	58.4	20.4	30.3	29.2
SE36D-HHB	21.8	6.0	10.5	5.3	47.1	69.5	66.9	40.8	60.3	58.0	20.4	30.1	29.0
SE36D-TTT	22.5	6.0	8.25	8.25	59.6	59.6	68.7	51.5	51.6	59.5	25.8	25.8	29.9
SE36D-BBB	21.6	6.0	7.8	7.8	57.6	57.6	64.9	49.9	49.9	55.3	25.0	25.0	28.1
SE36D-TTB	21.8	6.0	10.5	5.3	47.1	69.5	67.0	40.8	60.3	58.0	20.4	30.1	29.0
SE36D-TTH	21.9	6.0	10.6	5.3	47.1	70.0	67.4	40.8	60.7	58.4	20.4	30.3	29.2

OPTIONS AND ACCESSORIES

- 480VAC, 3 Phase
- Set of four, 6-1/4" high casters
- Extra intermediate slide-out oven rack
- Stainless steel sub-base
- Marine Kit Top

**INTENDED FOR COMMERCIAL USE ONLY.
NOT FOR HOUSEHOLD USE.**



1100 Old Honeycutt Road, Fuquay-Varina, NC 27526
(919) 762-1000 www.southbendnc.com