



BEVERAGE-AIR

3779 Champion Blvd., Winston-Salem, NC 27105
1-888-845-9800 Fax# 1-336-245-6453
<http://www.Beverage-Air.com>

Commercial Refrigeration Equipment General Specification

SPE ELITE SERIES — MEGA TOP, DUAL SIDED

Dual Sided Prep Table Cabinets are accessible from front and back. Fifty percent greater pan capacity than the all around standard prep table. Features enhanced refrigeration system and new and improved grille system for better airflow and less temperature gradient. Improved design provides better airflow management and uniform temperature distribution throughout the cabinet. Pans are cooled from the bottom, eliminating the necessity of air blanket. Airflow assures that product in open containers is kept below 41°F and above freezing. This translates into increased product shelf life, higher quality food, better food appearance, fresher product and a reduction of bacteria build-up to combat food-borne illnesses.

CABINET CONSTRUCTION

Exterior construction includes heavy-duty stainless steel finish on front, back, sides, top, and door(s). Removable hoods and insulated lid(s) assemblies are made of matching stainless steel.

Doors are mounted to face of cabinet on cartridge style hinges permitting them to self close. Hinges also allow doors to stay open 120°. A plug in type vinyl magnetic gasket is attached to each door for positive seal. Door handles are made from extruded aluminum with a black anodized finish. They are contoured to permit easy opening of doors with fingers from both top and bottom of handle.

Cabinet insulation is CFC and HCFC-free foamed-in-place polyurethane of two-inch minimum thickness. Six-inch casters, 2 with brakes, are standard. 3-inch casters and 6" legs are available as an option.

One (1) 10" deep and one (1) 12" deep, full length removable cutting boards constructed of high-density white polyethylene plastic are supplied with cabinet. These are readily removable for cleaning. Two epoxy-coated steel wire shelves per section are supplied as standard. Pans furnished are 4" deep and made of polycarbonate plastic.

REFRIGERATION

More robust refrigeration system provides added capacity and efficiency. Systems are designed using CFC and HCFC-free R134a refrigerant and capillary tube between condenser and evaporator. Recirculated, forced air from evaporator is moved under pans, which are recessed 2" from top of cabinet. Forced air over the condenser is drawn through grille under door as well as the back and bottom of cabinet. Automatic condensate evaporator is provided to eliminate the need of floor drains.

Item No. _____
Quantity _____

**FOOD PREPARATION
SERIES PREP TABLES
ELITE SERIES
MEGA TOP
DUAL SIDED**

**MODELS:
SPE27-12M-B-DS
SPE48-18M-DS
SPE60-24M-DS
SPE72-30M-DS**

**Optional Overshelf
Assembly Available**



SPE48-18M-DS



ELECTRICAL CONNECTION

Units pre-wired at factory and include 8' long cord and plug



115/60/1
NEMA-5-15P

Available From:



Model Specified _____	Store# _____
Location _____	Quantity _____



Food Preparation Table — Mega Top, Dual Sided
Models: SPE27-12M-B-DS, SPE48-18M-DS, SPE60-24M-DS, SPE72-30M-DS

MODEL	SPE27-12M-B-DS	SPE48-18M-DS	SPE60-24M-DS	SPE72-30M-DS
EXTERNAL DIMENSIONAL DATA				
Length Overall (inches)	27"	48"	60"	72"
Length Overall (mm)	686	1219	1524	1829
Depth Overall (inches)	48 1/2"	48 1/2"	48 1/2"	48 1/2"
Depth Overall (mm)	1232	1232	1232	1232
Height Overall— (inches) with lids open	46 1/2"	46 1/2"	46 1/2"	46 1/2"
Height Overall— (mm) with lids open	1181	1181	1181	1181
Number of doors	1	2	2	3
Depth with Door Open 90 °	62 1/2"	62 1/2"	62 1/2"	62 1/2"
Clear Door Opening (inches)	19 3/8" x 22"	19 3/8" x 22"	19 3/8" x 22"	19 3/8" x 22"
INTERNAL DIMENSIONAL DATA				
NET Capacity (cubic ft.)	7.3	13.9	17.1	21.5
NET Capacity (Liters)	207	394	484	609
Internal Length Overall (inches)	23"	44"	56"	68"
Internal Length Overall (mm)	584	1118	1422	1727
Internal Depth Overall (inches)	20"	20"	20"	20"
Internal Depth Overall (mm)	508	508	508	508
Internal Height Overall—(inches)	18"	18"	18"	18"
Internal Height Overall—(mm)	457	457	457	457
Number of shelves	2	4	4	6
Number of pans	12 1/6 size	6 1/6 size 2 1/2 size 1 full size	12 1/6 size 2 1/2 size 1 full size	18 1/6 size 2 1/2 size 1 full size
ELECTRICAL DATA				
Full Load Amperes 115/60/1	4	5	9.6	9.6
REFRIGERATION DATA				
Horsepower	1/6	1/4	1/3	1/3
WEIGHT DATA				
Gross Weight (Crated lbs)	244	378	447	465
Gross Weight (Crated kg)	111	172	203	211

PLAN VIEWS

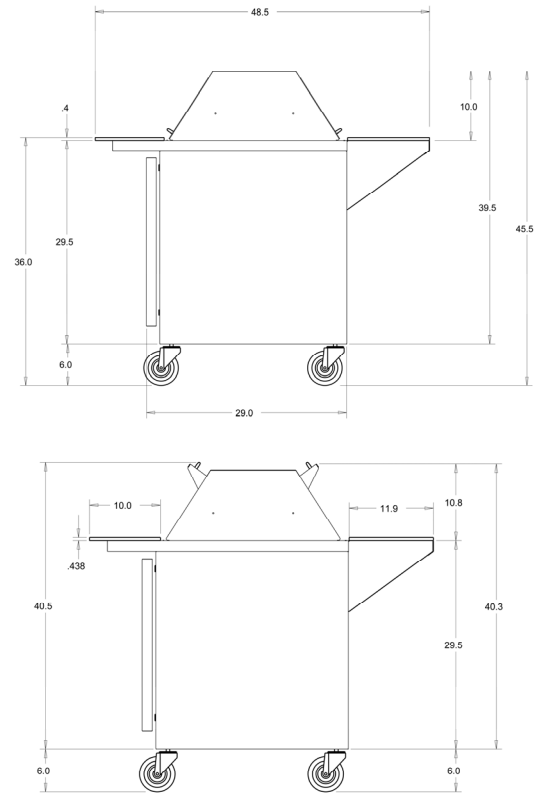

COMMON END VIEWS

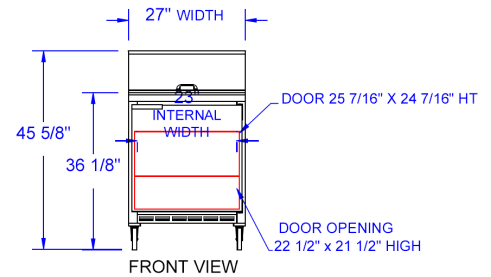

SPE27 FRONT VIEW

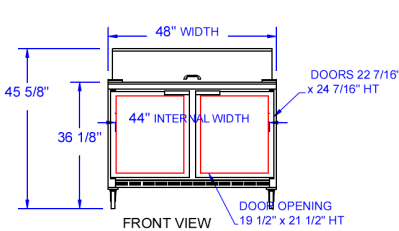

SPE48 FRONT VIEW

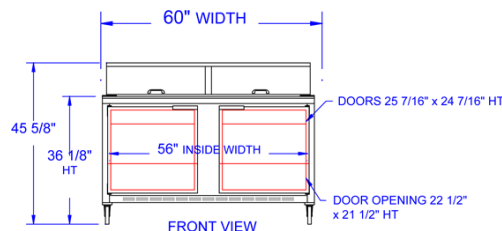

SPE60 FRONT VIEW

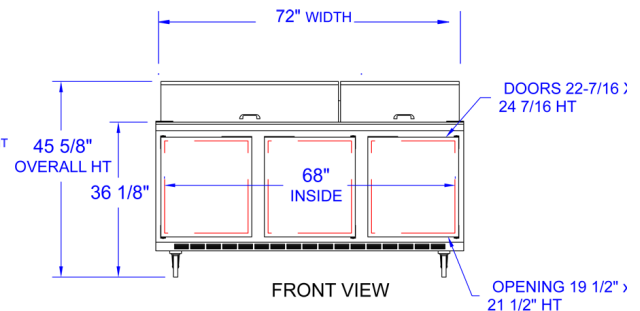

SPE72 FRONT VIEW

BEVERAGE-AIR® CORPORATION

3779 Champion Blvd. • Winston-Salem, NC 27105 USA • (336) 245-6400 • Fax (336) 245-6453 • (888) 845-9800 • www.beverage-air.com

Specifications are subject to change without prior notice. 03/11