

# ELECTRIC COUNTER FRYERS (SINGLE AND DOUBLE)

**B-10M  
B-10M2**



**MODELS  
B-10M  
B-10M2**



PROJECT \_\_\_\_\_

ITEM \_\_\_\_\_

## **DESCRIPTION**

- Stainless steel top, front and backsplash
- Removable grease container(s).
- Pre-heats to 350°F (177°C) in approximately 6 minutes.
- Lift handle(s) located in front of the fryer for raising and lowering of the element(s).
- 15 lbs. (8.5 L) fat capacity per grease container.
- Four (4) individual baskets are supplied with B-20M2 model, two with B-10M model.
- Thermostat control is located in front of fryer to assure greater safety.
- Thermostat maintains temperature from 200°F to 400°F (93°C à 204°C).

## **OPTIONS**

- 12" stainless steel removable drainboard.
- Stainless steel sides and back.
- Stainless steel night cover.

M.K.E. Industries (1984) Inc.

183 Montcalm Blvd. N. Candiac Qc J5R 3L6 Tel: (450) 659-6531 / 1-800-361-9801 / Fax: (450) 659-2248

[www.mke-ind.com](http://www.mke-ind.com)

10/02

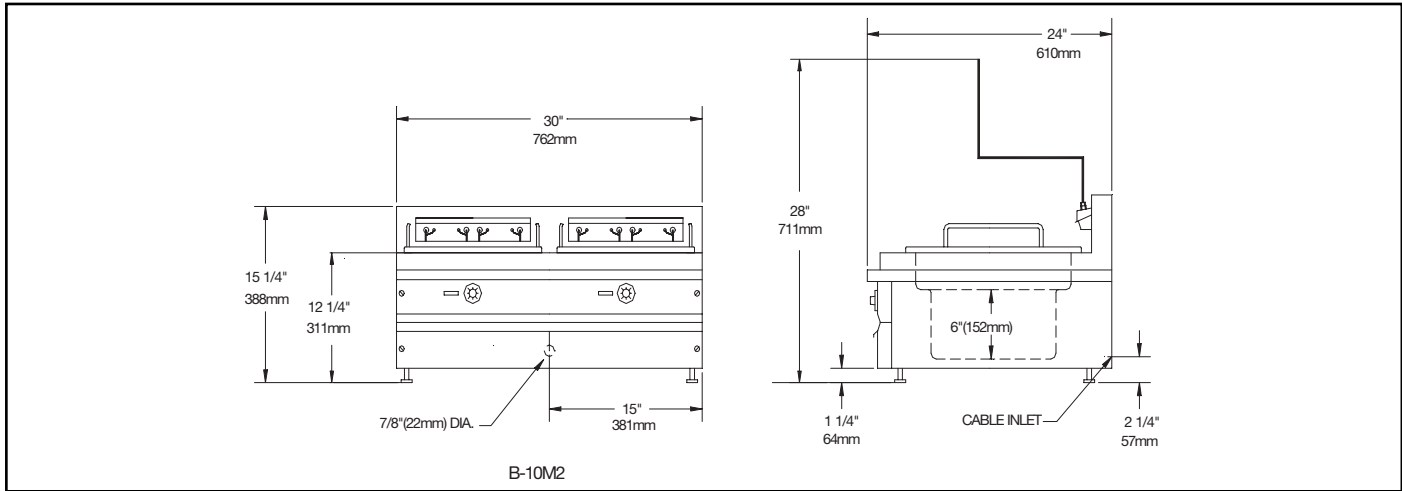

B-10M2

Model	Length	Depth	Height	Power	1 phase current (Amps)		Volume	Weight
					208V	240V		
B-10M	15" 381 mm	24" 610 mm	15 1/4" 387 mm	6000 W	29	25	33 ft <sup>3</sup> 0.09 m <sup>3</sup>	58 lbs. 26.3 kg
B-10M2	30" 762 mm	24" 610 mm	15 1/4" 387 mm	12000 W	58	50	6.66 ft <sup>3</sup> 0.18 m <sup>3</sup>	138 lbs. 62.6 kg

SPECIFICATIONS ( Approximate hourly capacity )		B-10M	B-10M2
Potatoes	from raw to fried	30 lbs. 13.6 kg	60 lbs. 27.2 kg
	from frozen to blanched	42 lbs. 19.1 kg	84 lbs. 38.1kg
	from white to browned	120 lbs. 54.4 kg	240 lbs. 108.9 kg
Chicken ( 2 lbs. / 0.9 kg )	raw piece to fried	15 lbs. 6.8 kg	30 lbs. 13.6 kg
Fish portion ( 1 oz / 28.5 g )		20 lbs. 9.1 kg	40 lbs. 18.2 kg

**REQUIRED CLEARANCE**

- Adapted for installation on a combustible surface.
- For installation on or near combustible materials.
- Required minimal distances are:  
1 inch from the sides  
1 inch from the back

**\* FOR COMMERCIAL USE ONLY**

\* Specifications may change without notice due to continuous product improvement